

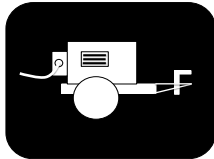

> we move it faster >

4HS

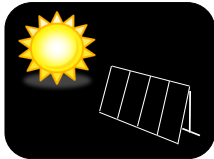
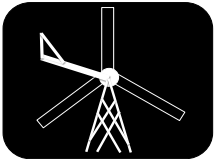

MultiPower

4" submersible pumps
with integrated electronics
powered by renewable
energy sources



new range



4HS technology applied to renewable energy

4HS MultiPower pumps (4HS MP), powered by renewable energy sources, is a new range coming from the 4HS pumps with built-in inverter.

4HS MultiPower pumps may be powered by AC or DC with a wide range of operating voltage (90 - 265 VAC / 90 - 400 VDC).

This means that 4HS MP pumps can be connected to solar panels, batteries, wind turbine and diesel generator.

A special software algorithm allows for adjusting the hydraulic performance to each source and to the available power while maximizing the pumped water.



All the advantages of built-in electronics

The built-in electronics inside the motor avoids the use of shielded cables and output filters and it is the ideal solution for any application in remote locations without surveillance and climatically adverse.

In fact, in the traditional solutions, the solar inverter is placed above ground and, being exposed to the weather, could suffer of:

- Overheating
- Water infiltration
- Thermal shock
- Damaging by animals or people

4HS MultiPower pumps do not need of any external electronic component; it is just enough to connect

the pump cable to the power source and start to extract water.

The built-in electronic is directly cooled by the water flow; the operating temperature of the electronic components is so low as to ensure considerably longer a life than a on-surface inverter affected by high temperature, humidity, dust and solar radiation.

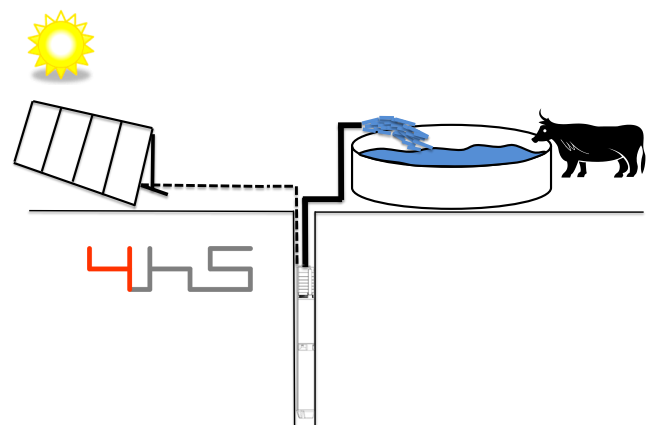
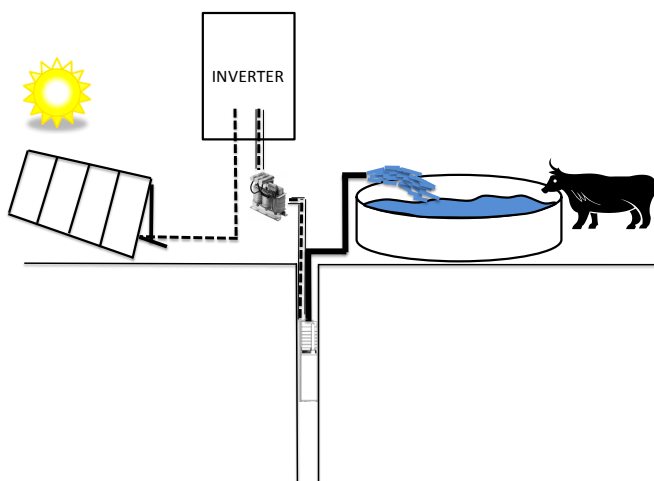

Simplified maintenance



4HS pumps are entirely made of stainless steel AISI 304 to grant a long life of the components.

Pump, motor and hydraulic components can be easily disassembled to have simple maintenance and replacement operations.

Centrifugal pump

- Impellers and diffusers in stainless steel.
- Built-in no return valve.



Motor

- AC permanent magnet motor
- Resined and encapsulated stator made of stainless steel AISI 304.
- Water cooled rotor.
- Kingsbury thrust bearing.



Built-in inverter module (MINT)

- Completely filled of resin.
- Removable power cable.



Simplified maintenance



The helical rotor pump

The 4HS “H” pumps are equipped with a helical rotor that moves within a double helix rubber stator.

The rotor is made of AISI 316 stainless steel and coated with a hard chrome surface.

During operation, the rotor moves on the rubber surface and it's lubricated by the pumped water.

The flow rate is directly proportional to pump speed while the pressure supplied is kept almost constant.

In this way, unlike a centrifugal pump, the helical rotor pump provides high head even at low rpm, ensuring water on surface even with very low available power or low irradiation.

In addition, the helical rotor pumps feature higher hydraulic efficiency than centrifugal pumps of same flow. This saves in the number of PV panels necessary for the application.



Permanent magnets motor

The 4HS MP pumps are equipped with AC permanent magnets motor.

The rotor uses Neodymium magnets coated with thin layers of Copper and Nickel, to ensure, in addition to superior magnetic performance, greater reliability and durability.

High motor efficiency and high starting torque make pump moving even in low light conditions.

The integrated inverter module realizes the conversion from DC energy into useful electrical energy to drive the engine efficiently and, at the same time, adjusts the pump speed in relation to available irradiation, maximizing the power extracted (MPPT).

Over-current, over-temperature, lack of water protections are integrated on-board.



MPPT: Maximum Power Point Tracking

In the application with solar panel, the function MPPT (Maximum Power Point Tracking) maximizes the input power for various conditions of radiation and temperature.

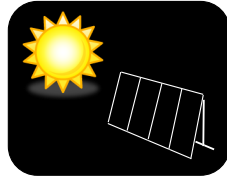

When radiation grows, pump increases the rotation speed as well as the water flow .

When radiation decreases (presence of clouds or different hours of the day), pumps reduces the speed and thus the water flow but still provide water until the radiation falls below the minimum value to ensure the operation.

Installation

4HS MultiPower pump can be installed with CM MultiPower control module or without it, so becoming a “plug and pump” system.

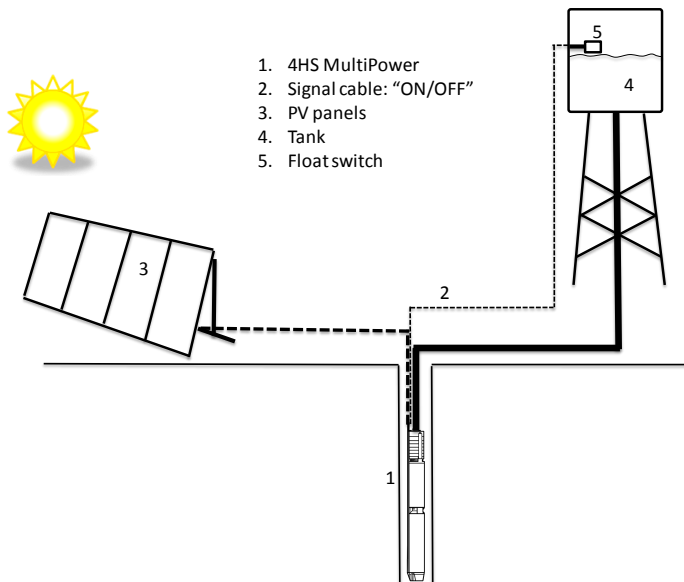

If the CM MultiPower control module is not used, signal cables can be used to control pump ON/OFF the connecting, for example, a float switch.

All the protections against overload, overvoltage and dry running are integrated into the on board inverter.

If the signal cables are connected to the CM MultiPower control module, it is possible to:

- Control the electric parameters (current, power, voltage).
- Record and store all the alarms related to the working hours.
- Connect a pressure or a flow sensor to control the pump performances.



- Connect a pressure or float switch.
- Provide an alarm digital output for remote control.

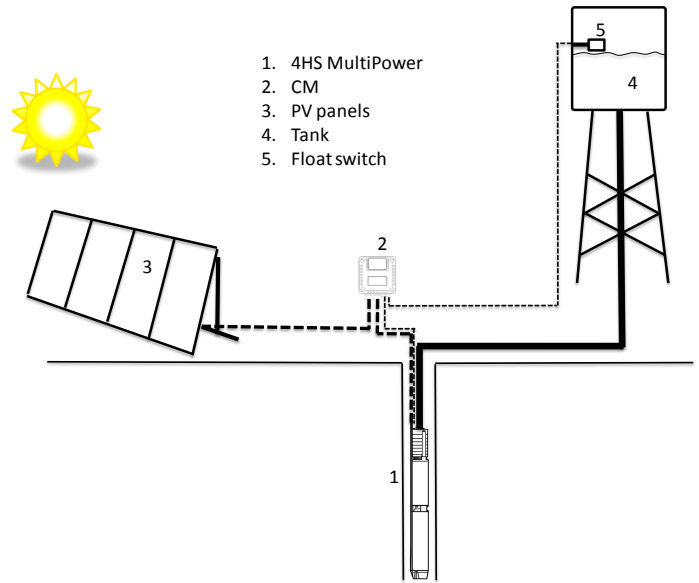

Use of auxiliary genset

If solar energy is absent or not enough, it is possible to feed the pump with an auxiliary genset to grant the desired pump performances.

An AC/DC selector is used to change the power source.

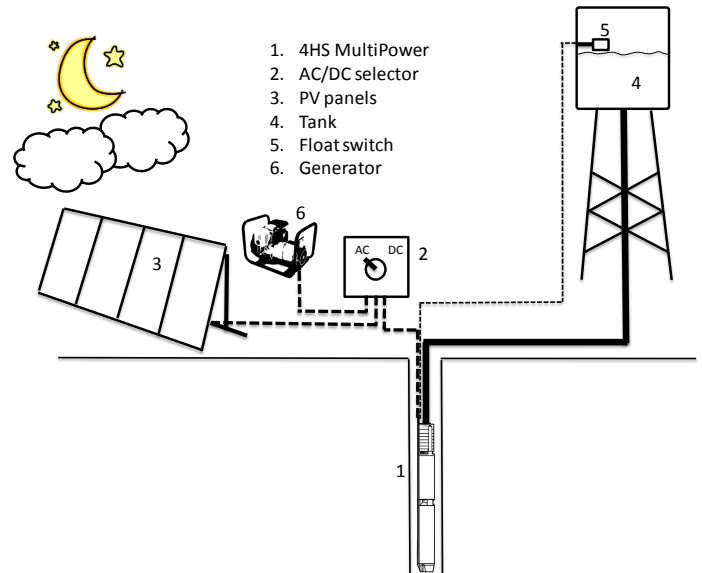

Integrated on board protection

Protections against overvoltage, overload and dry running are integrated into the pump electronic circuit.

Electronic protection against dry running avoids the use of the probes.

Pump selection in a PV system

For the correct selection of a 4HS MultiPower pump to be used in a photovoltaic (PV) system, it is necessary to know:

- Desired daily water quantity.
- Total head (static + dynamic).
- Installation location.
- Working period (seasonal or year).

Based on location it is possible to get from maps and tables (available in the web) the following values:

- Average daily radiation per year, minimum and maximum (kWh/m²)
- Average daily radiation per months, minimum and maximum.
- Optimal tilt angle of the photovoltaic panels.

Starting from daily radiation could be considered the number of hours with 1kW/m², standard value to which PV panels performances are referred.

Dividing the required water quantity by the hours, nominal pump is calculated and, in addition to the required head, the right pump could be selected.

Our technical department is available in assisting you in this.

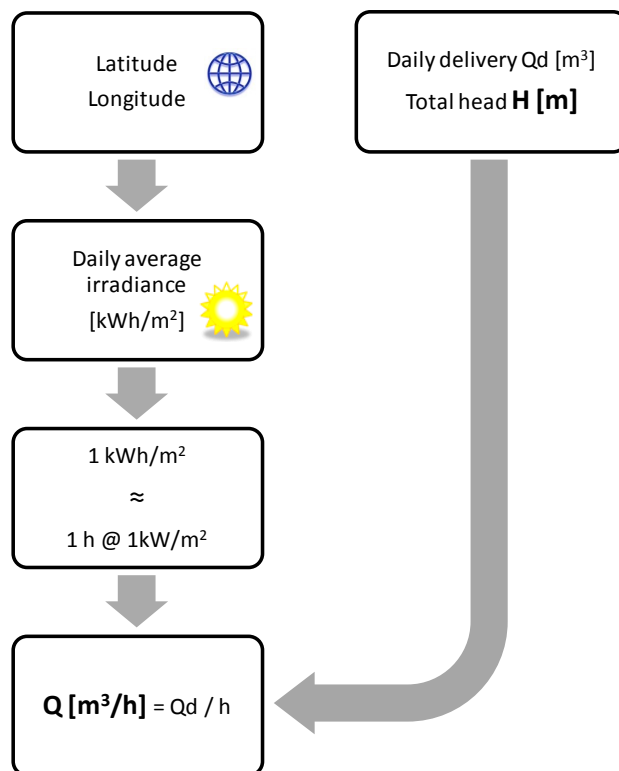

Sizing example

Daily delivery **Qd = 26 m³**

Total head **H = 50 m**

Location : Mossano, Vicenza, Italia

Latitude: 45° 25'

Longitude: 11° 33'

Optimal tilt angle is 35°.

If the pump is used the full year, have to be considered the average daily radiation per year that is 3,85 kWh/m² (3,85 h @ 1kW/m²) and, considering the required daily delivery Qd, a pump granting $26/3,85 = 6,75$ m³/h should be selected.

If the pump is used only in the summer (June, July, August), have to be considered the average daily radiation for the selected months that is 6,05 kWh/m² (6,05 h @ 1kW/m²).

Mossano	kWh/m ²
January	1,54
February	2,44
March	3,72
April	4,81
May	5,81
June	6,34
July	6,39
August	5,42
September	4,16
October	2,69
November	1,73
December	1,19
Year	3,85

	Year	Summer
Q [m ³ /h]	6,75	4,3
H [m]	50	50
4HS MultiPower	05/08	05/04
P1 [W]	2650	1400
PV panels	12	6
Series	6	6
Parallel	2	0

* Sizing considering 240 Wmpp photovoltaic panels, 30 Vmpp nominal voltage , 8 Impp nominal current, 38 Voc no load voltage.

Performance

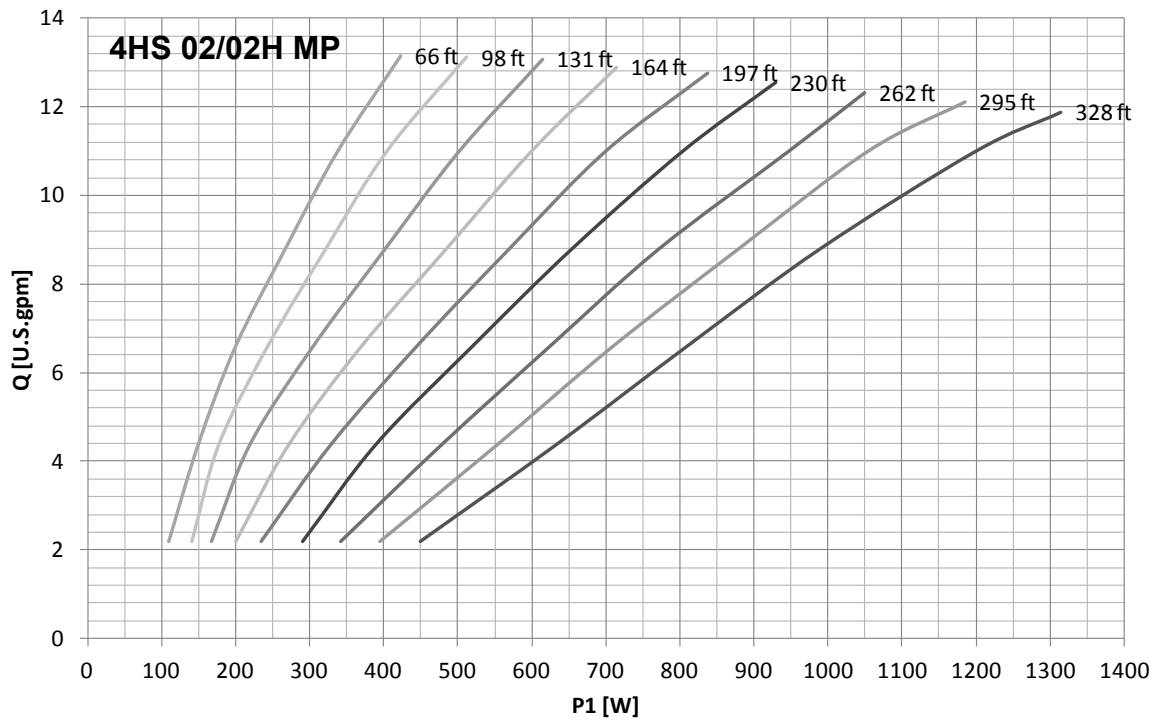
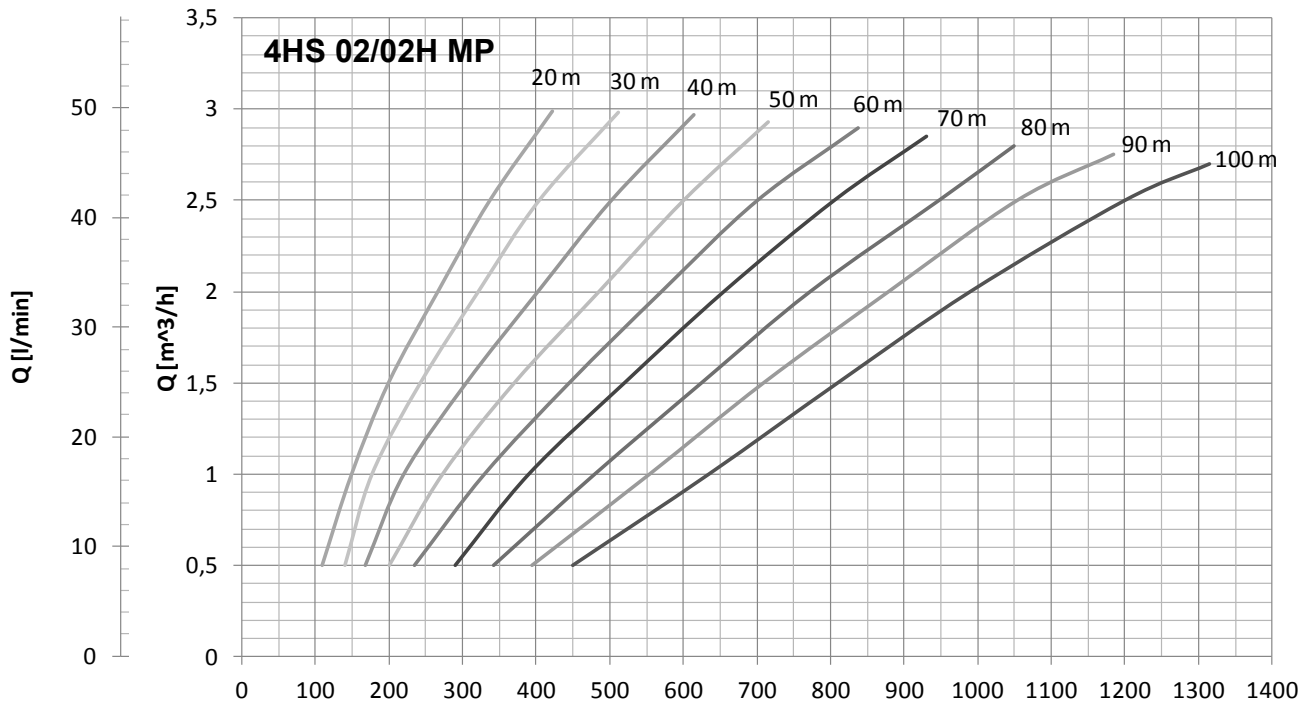

Model	Voltage	Max. absorbed current	Power factor	Max absorbed power	Dimension	Delivery	Pump weight	Max. diameter	Packing size	Total weight
4HS		[A]		P1 [W]	[mm]		[kg]	[mm]	[cm]	[Kg]
02/02H MP	90 - 400 VDC 90 - 265 VAC	13 (100 VDC) 13 (100 VAC)	1	1300	1350	1 1/4 "	19,5	101 *	120x20x29	20,5

* Max. external diameter including cable and cable cover

Performance

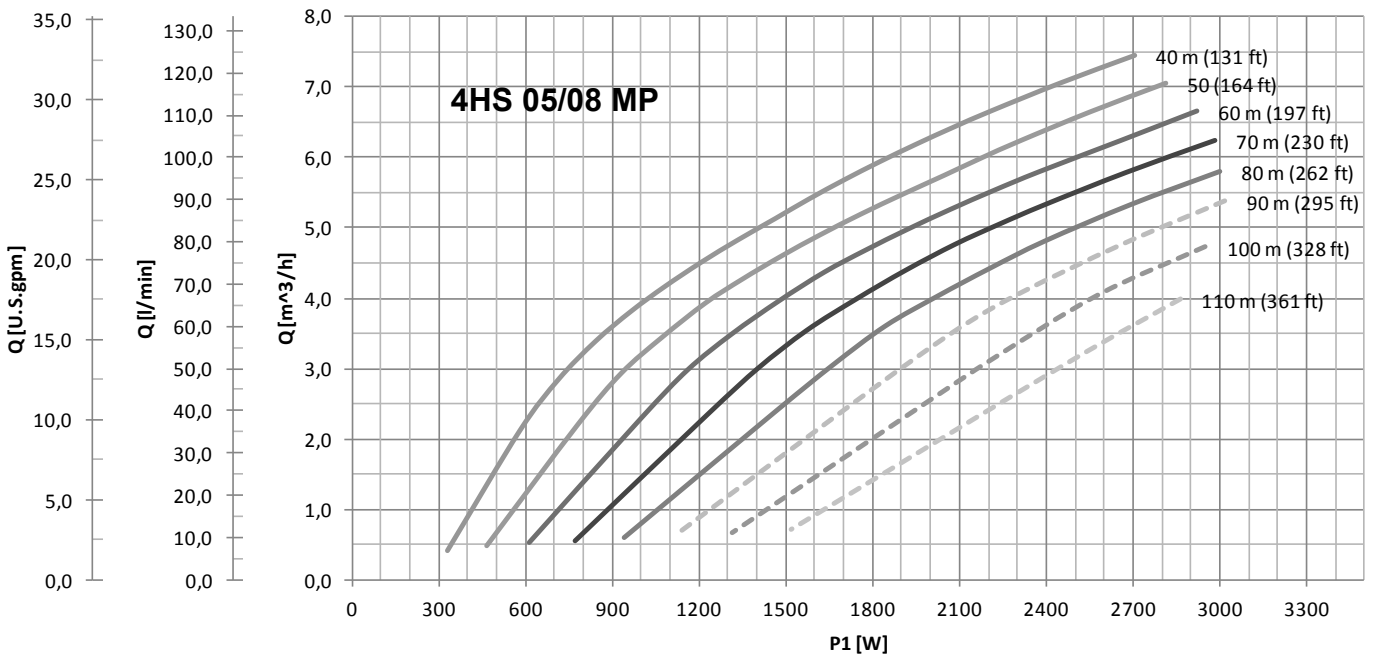
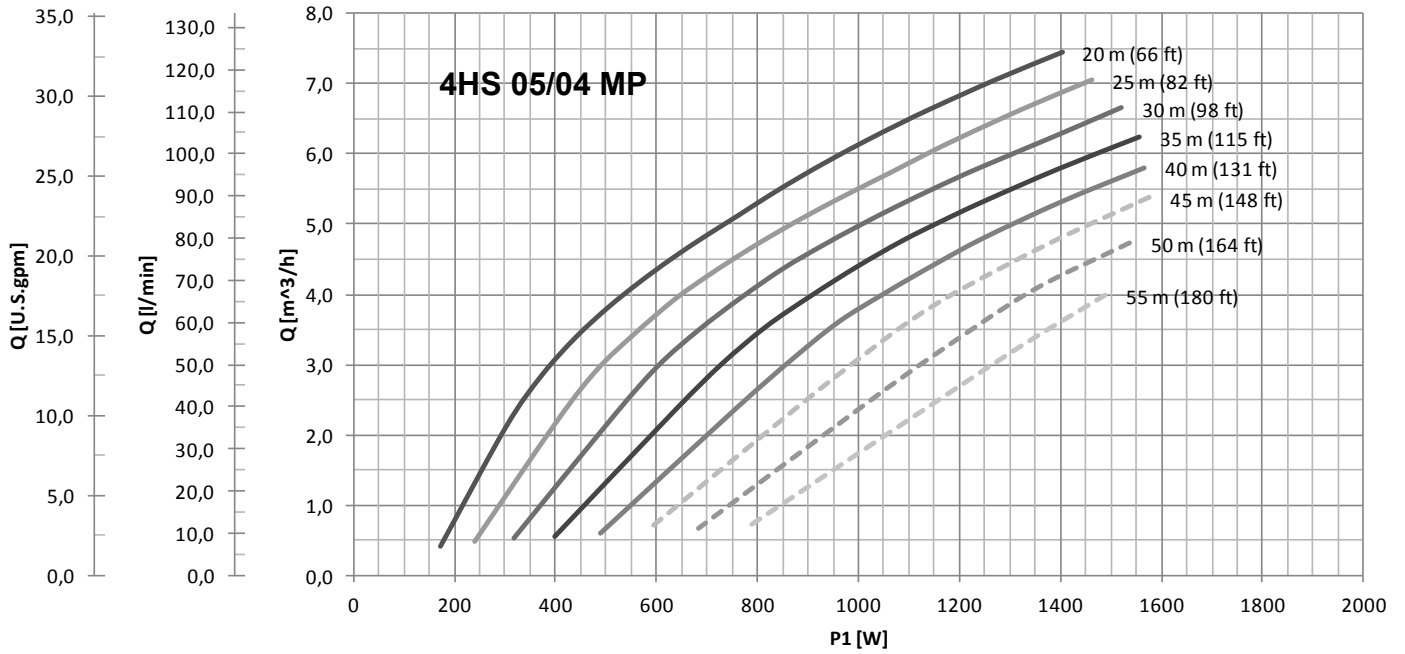

CM MultiPower installation is recommended on dashed lines operation.

Model	Voltage	Max. absorbed current	Power factor	Max absorbed power	Dimension	Delivery	Pump weight	Max. diameter	Packing size	Total weight
4HS		[A]		P1 [W]	[mm]		[kg]	[mm]	[cm]	[Kg]
05/04 MP	90 - 400 VDC 90 - 265 VAC	16 (100 VDC) 16 (100 VAC)	1	1600	879	1 1/2 "	19,5	101 *	120x20x29	20,5
05/08 MP	90 - 400 VDC 90 - 265 VAC	16 (187 VDC) 16 (187 VAC)	1	3000	1013	1 1/2 "	22	101 *	120x20x29	23

* Max. external diameter including cable and cable cover

Performance

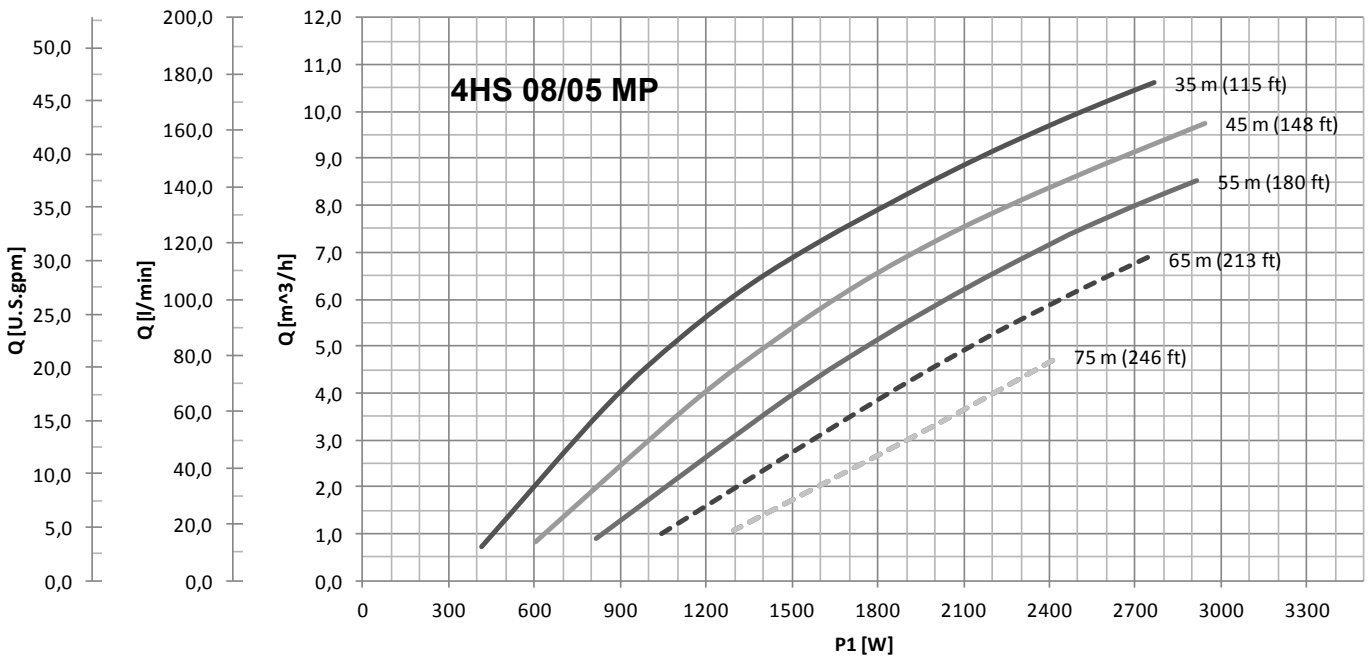
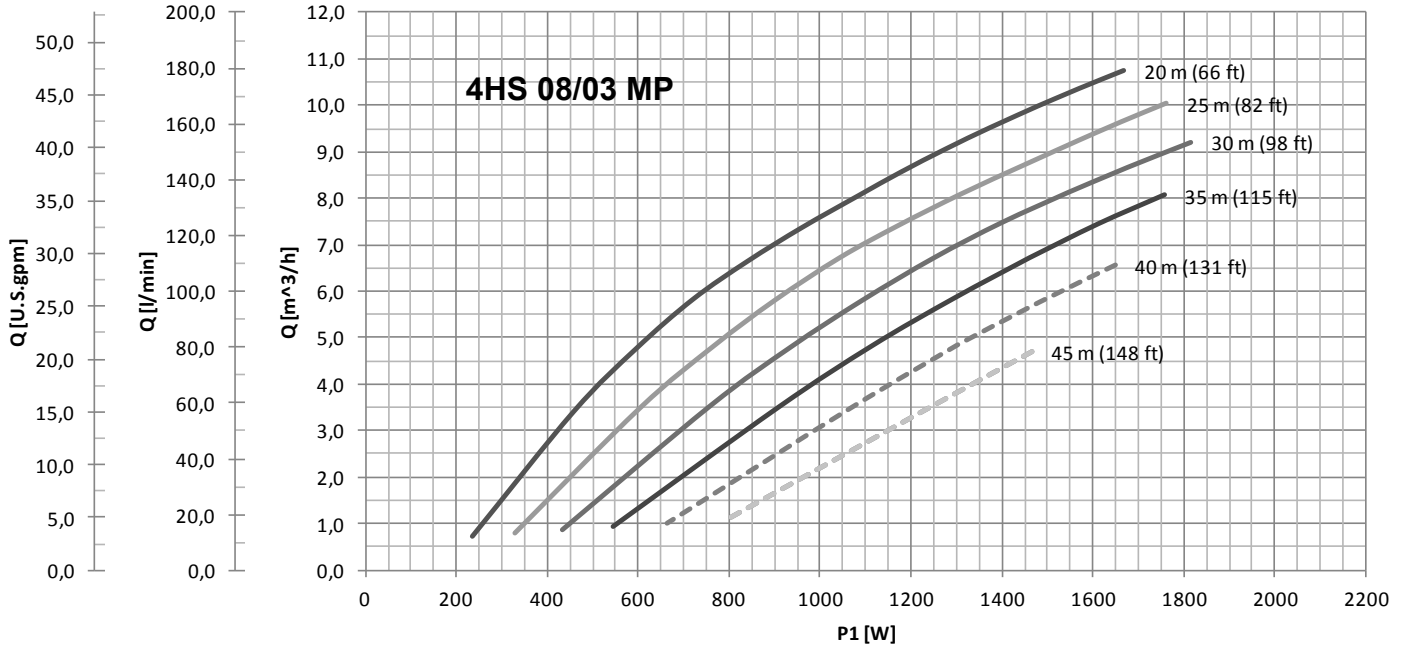

CM MultiPower installation is recommended on dashed lines operation.

Model	Voltage	Max. absorbed current	Power factor	Max absorbed power	Dimension	Delivery	Pump weight	Max. diameter	Packing size	Total weight
4HS		[A]		P1 [W]	[mm]		[kg]	[mm]	[cm]	[Kg]
08/03 MP	90 - 400 VDC 90 - 265 VAC	16 (113 VDC) 16 (113 VAC)	1	1800	858	1 1/2 " 2"	19,4	101 *	120x20x29	20
08/05 MP	90 - 400 VDC 90 - 265 VAC	16 (187 VDC) 16 (187 VAC)	1	3000	950	1 1/2 " 2"	21	101 *	120x20x29	22

* Max. external diameter including cable and cable cover

Materials

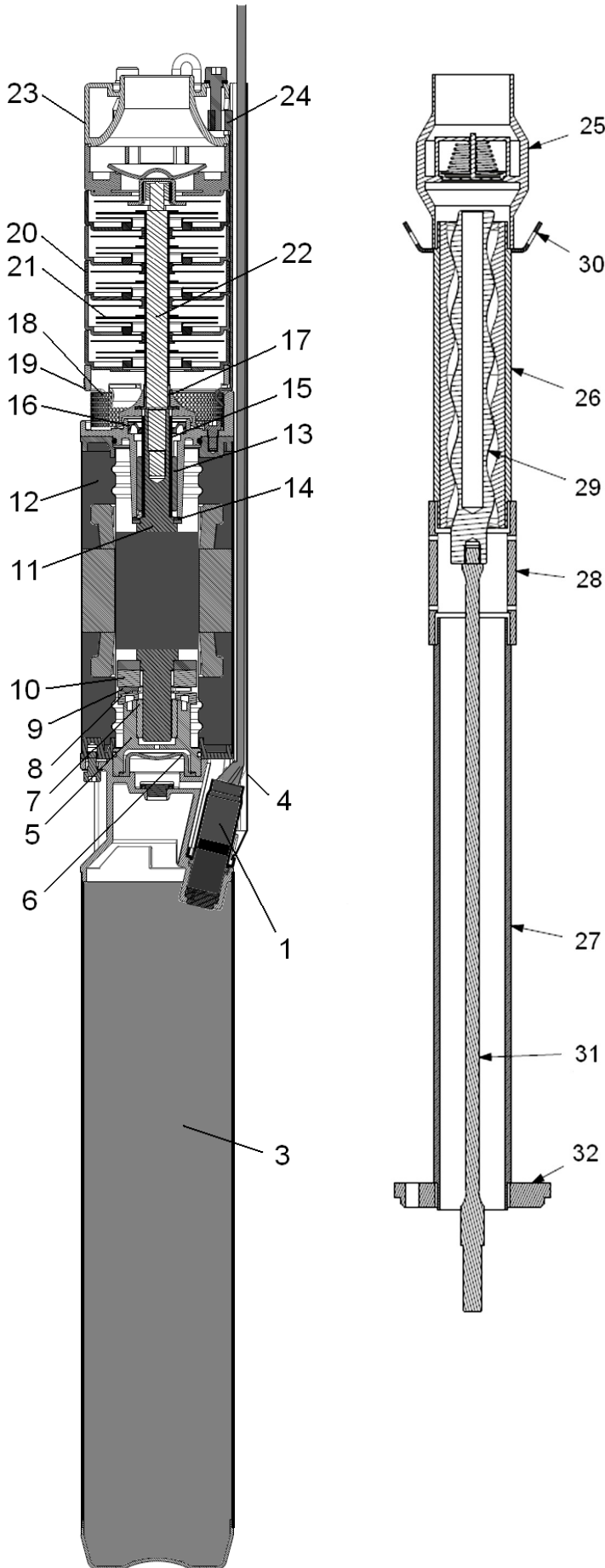

REF	DESCRIPTION	MATERIAL
1	Power supply removable connector with cable for drinking water applications	AISI 304 + ACS-KTM-WRAS compliant
3	MINT: Electronic Integrated Module	
4	Cable guard	AISI 304
5	Lower thrust bearing	AISI 304
6	Rubber diaphragm	EPDM
7	Lower carbon bush	CTI25
8	Tilting disc	AISI 304
9	Pads	AISI420j
10	Carbon disc	CTI25
11	Shaft with rotor	AISI 431
12	Canned type stator	AISI 304
13	Upper carbon bush	CTI25
14	Upper thrust bearing	Teflon
15	Ceramized sleeve	AISI 304 + Ceramic
16	Lip seal	FKM
17	Rotating sandguard	NBR
18	Pump filter	AISI 304
19	Pump bracket	AISI 304
Centrifugal pump		
20	Diffusers	AISI 304
21	Impellers	AISI 304
22	Pump shaft	AISI 304
23	Discharge	AISI 304
24	Straps	AISI 304
Helicoidal rotor pump		
25	No-return valve	AISI 304
26	Helicoidal stator	EPDM + AISI 304
27	Supporting pipe	AISI 304
28	Junction	AISI 304
29	Helicoidal rotor	AISI 316 cromed
30	Safety hook	AISI 304
31	Flexible shaft	AISI 316
32	Pump adaptor	AISI 304

General characteristics

4HS MultiPower	
Max. temperature of the liquid	35 °C (92 °F)
Min. cooling speed of the liquid	0.2 m/s
Characteristics of the pumped liquid	clean, chemically not aggressive, not explosive, without solids and fibres content, with max. 50 g/m ³ sand content
Protection grade	IP68
Max. immersion depth	150 m
Materials	Motor and pump in AISI 304 stainless steel
Cable	Flat cable ACS - WRAS - KTM approved

CM MultiPower Control Module	
Max. ambient temperature	50 °C (122 °F)
Protection grade	IP55
Materials	Aluminium enclosure, PVC labels , cable gland in polyamide (PA), display membrane in polyester (PE)
Analog input	2 input 4-20 mA + 2 input 4-20 mA or 0-10 V settable by the user
Digital input	4 input N.A o N.C settable by the user
Digital output	2 relays output 5 A , 250 VAC, N.A. o N.C settable by the user
User display	display LCD backlit, 16 characters x 2 rows, 5 buttons
Shortcircuit protection	by fuse

Certifications	
CE	

4HS MultiPower pump can be installed both vertically and horizontally with the outlet never be lower the horizontal axis.

To ensure a proper cooling if 4HS is not installed in a well, it is necessary to use a cooling sleeve to grant the minimum cooling speed of the liquid.

