

# wasteflo

## LS5 - Lifting Station

The Wasteflo LS5 lifting station is ideal when you need to create a shower room, kitchen or utility room anywhere in your home or commercial building. A bath, shower, basin, sink, washing machine and dishwasher can all be connected.

The Wasteflo LS5 lifting station is designed with an innovative removable cassette system, which houses the electrical and mechanical components. This cassette system allows for easy and clean access without having to remove any pipework or the appliance when servicing or maintaining the unit.



### Features

- Two top inlet connections suitable for dishwasher and washing machine.
- Three side inlets with non return valves suitable for 32 mm (1¼ ") or 40 mm (1½ ") waste pipe connections (inlet adaptor included).
- 32 mm (1¼ ") diameter waste outlet.
- Pumps up to 7 m vertically or 72 m horizontally.
- Maximum flow rate of 120 l/min.
- Complies with BS EN 12050.
- Typical 50 dB noise level.
- Supplied pre-wired with 1.5 m supply cable.

### Application

- The Lifting Station is a simple way to pump waste water from an appliance where there is no local access to a soil pipe.

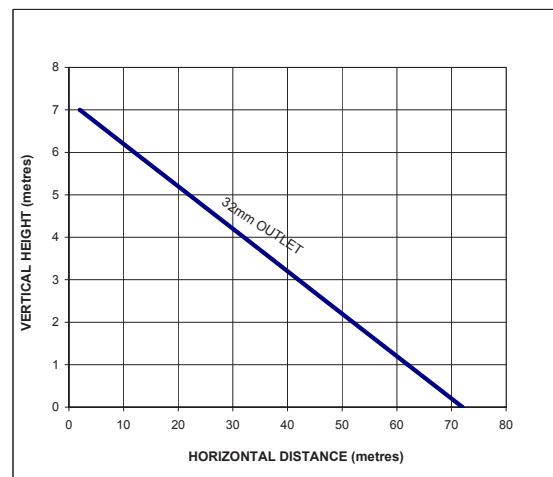

# wasteflo

Pump Model		LS5 46577
General	Guarantee	2 years
Features	Slimline design	✓
	Noise level	50 dB (typical)
Performance	Maximum head	7.7 metres
	Pumping distance (vertical)	Up to 7 metres
	Pumping distance (horizontal)	Up to 72 metres
	Maximum flow	120 l/min
	Maximum ambient air temperature	40 °C
	Min / Max water temperature	Min 4 °C / Max 50 °C (Continuous duty), Max 70 °C (short term rating)
Connections	Inlet(s)	32 mm (1 1/4 ") dia. (standard), 20 mm/G 3/4 elbow connection (washing machine)
	Outlet	32 mm waste pipe adaptor
Motor	Duty rating	Continuous
Electrical	Power supply / phase / frequency	230 V a.c. / 1 / 50 Hz
	Current (full load)	2.0 Amps
	Power consumption	460 Watts
	Fuse rating	5 Amps
	Power cable (pre-wired)	1.5 metres
Physical	Enclosure protection	IPX4
	Length	413 mm
	Width	180 mm
	Height (excluding hoses)	278 mm
	Weight (including fittings)	7.8 Kg

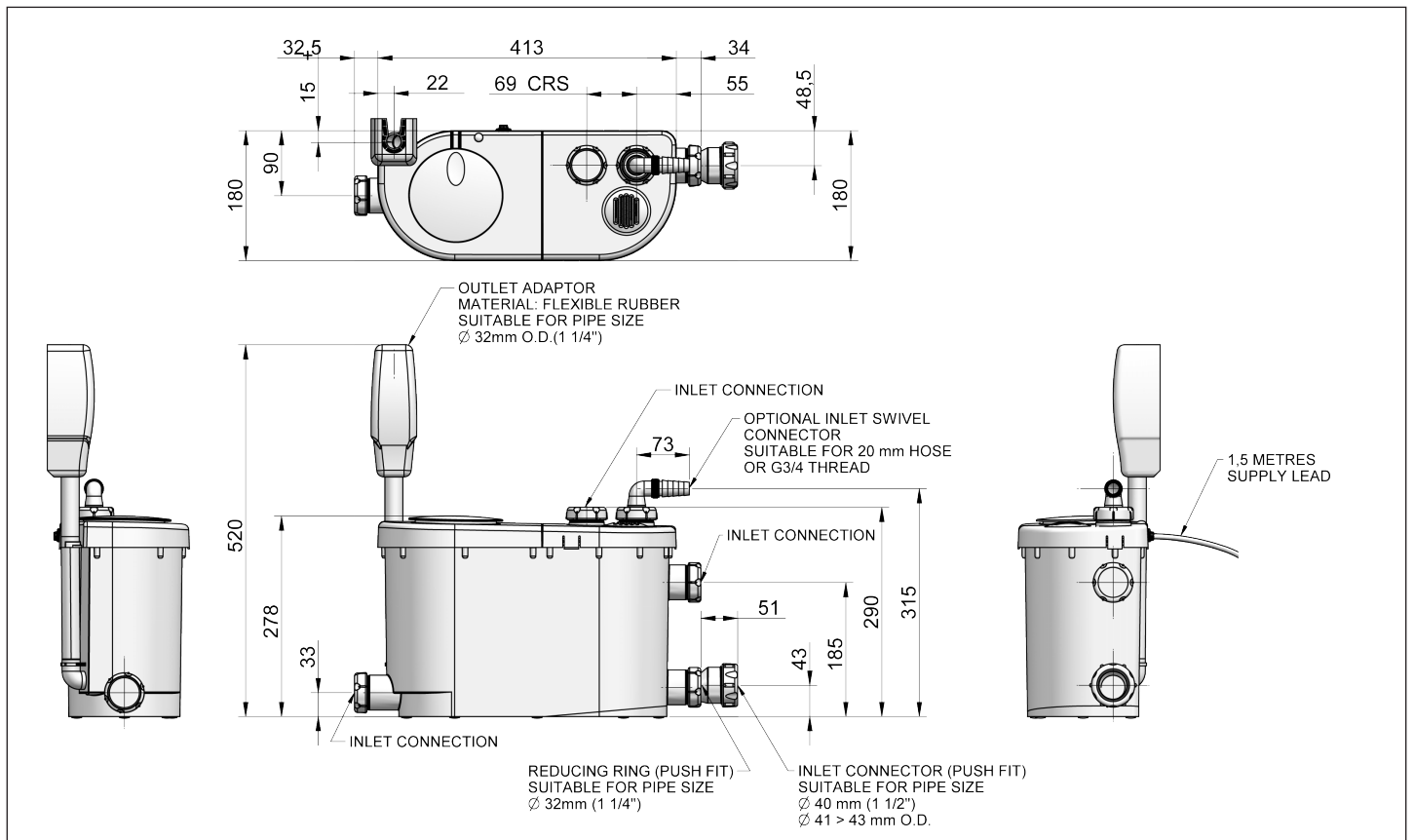

Stuart Turner Limited reserves the right to amend specifications without notice.

Stuart Turner Ltd, Henley-on-Thames, Oxfordshire RG9 2AD

Tel: +44 (0)1491 572655 Fax: +44 (0)1491 573704

www.stuart-turner.co.uk

Pt. No. 19619 Issue 1816/2-04

**pumpassist**  
HELPLINE +44 (0) 800 31 969 80